

Model	a (mm)
85	850
95	950
110	1100
125	1250
140	1400

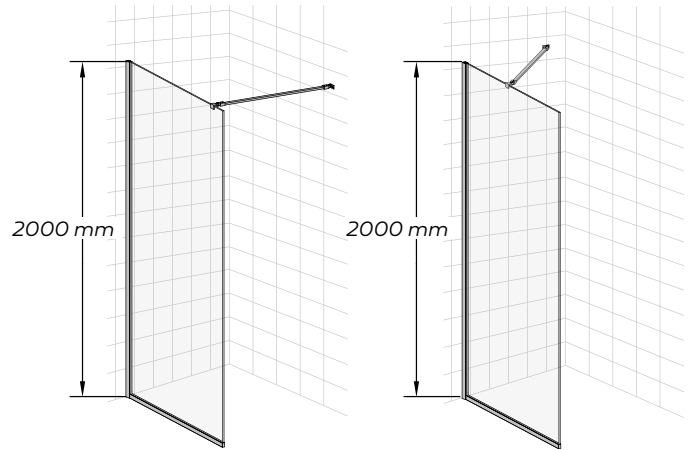
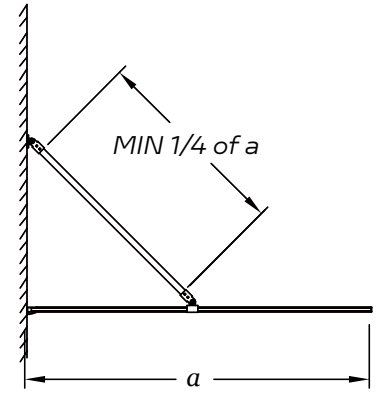

b

X1

c

X1

d

X1

e

X1

a

X1

!

f1

N3 X1

f2

N4 X1

g1

X1

g2

X1

h1

ST4x35mm X4

h2

ST4x35mm X2

i

X6

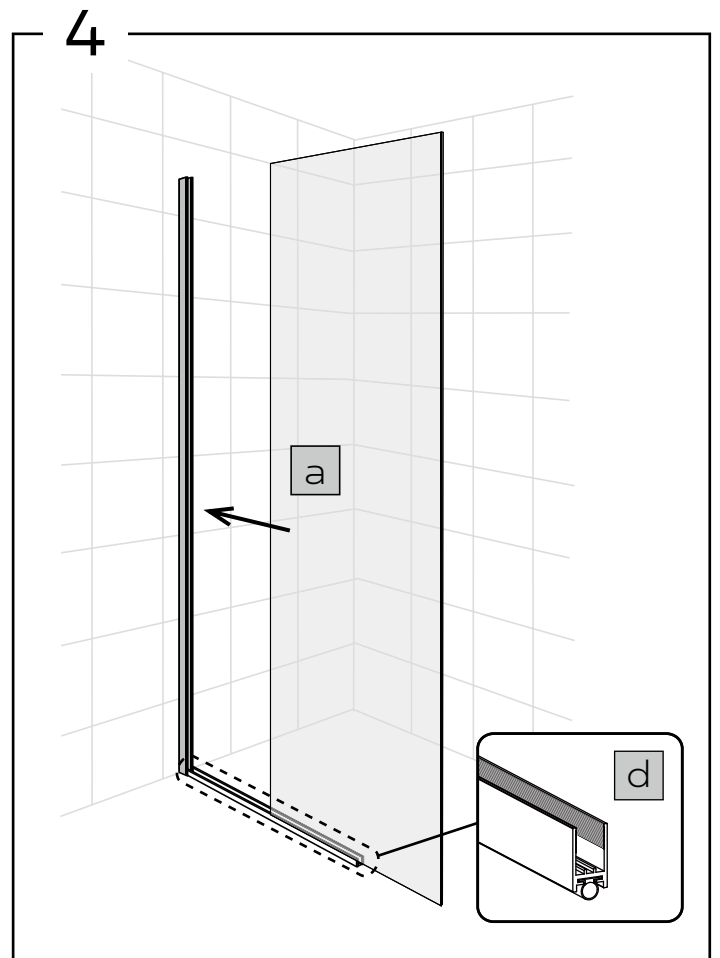
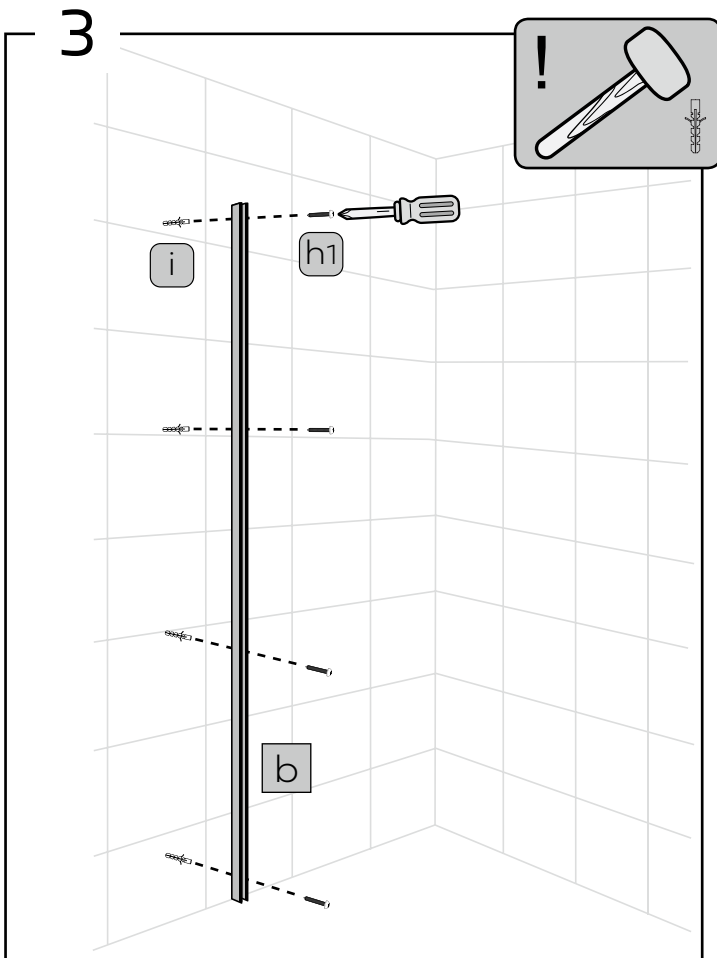
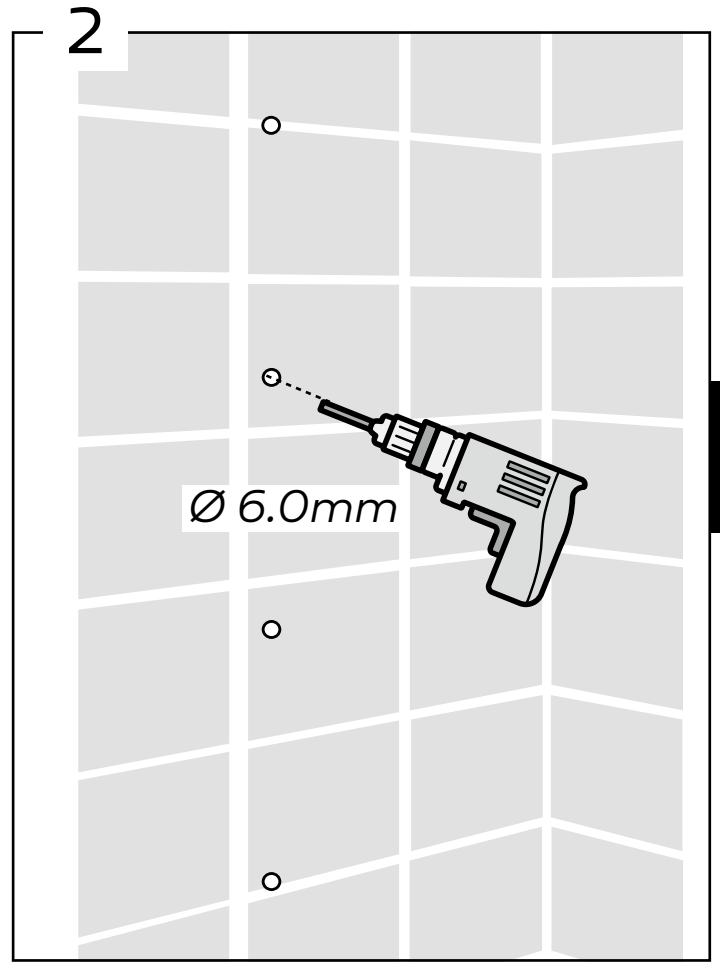
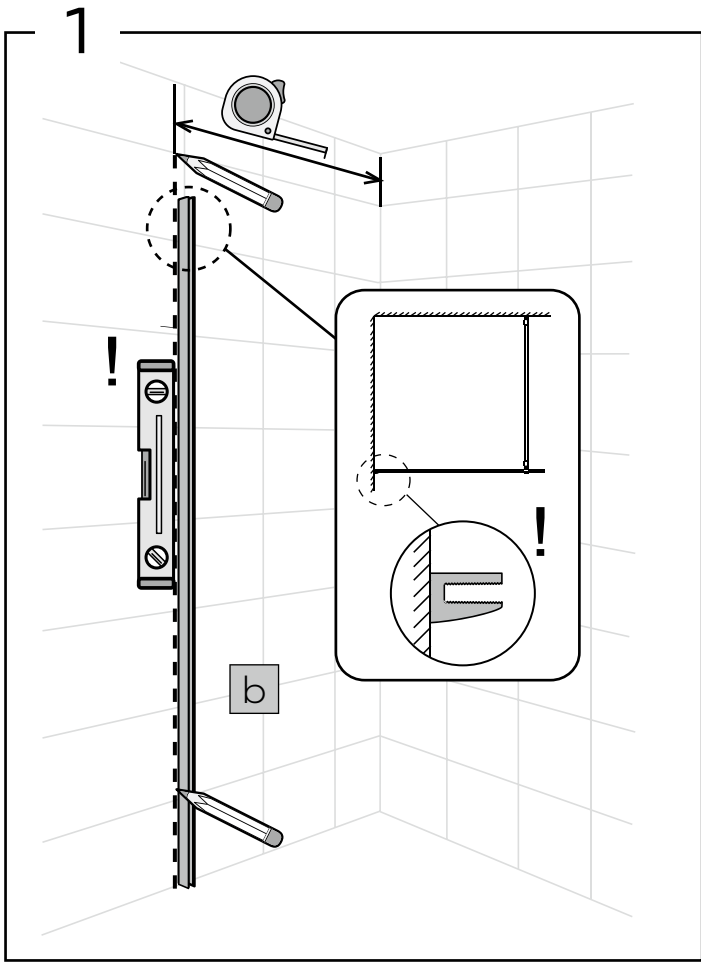

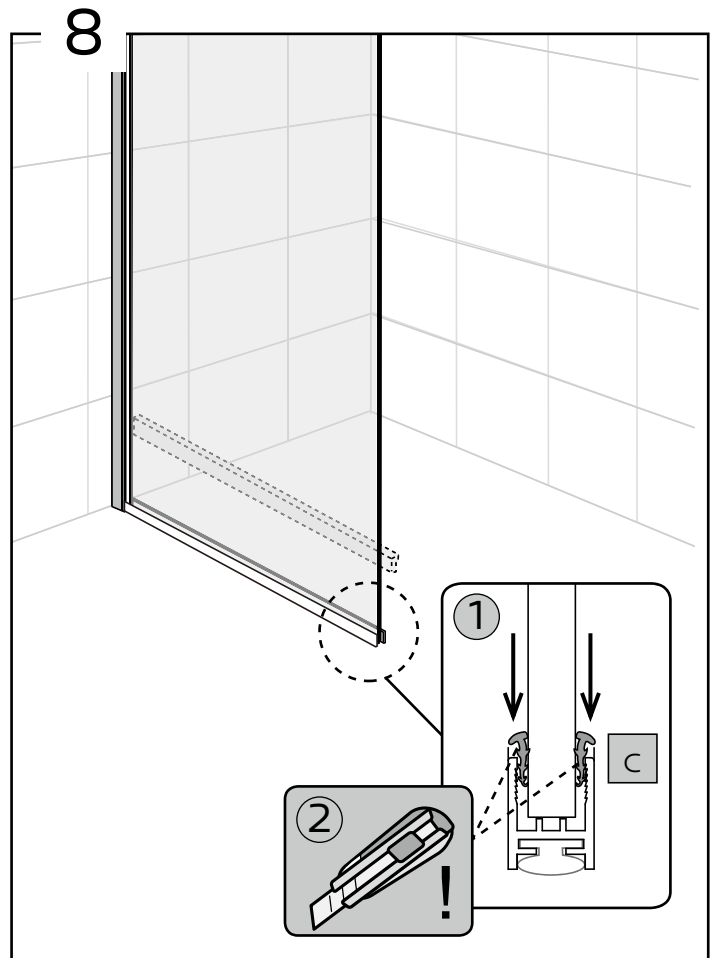
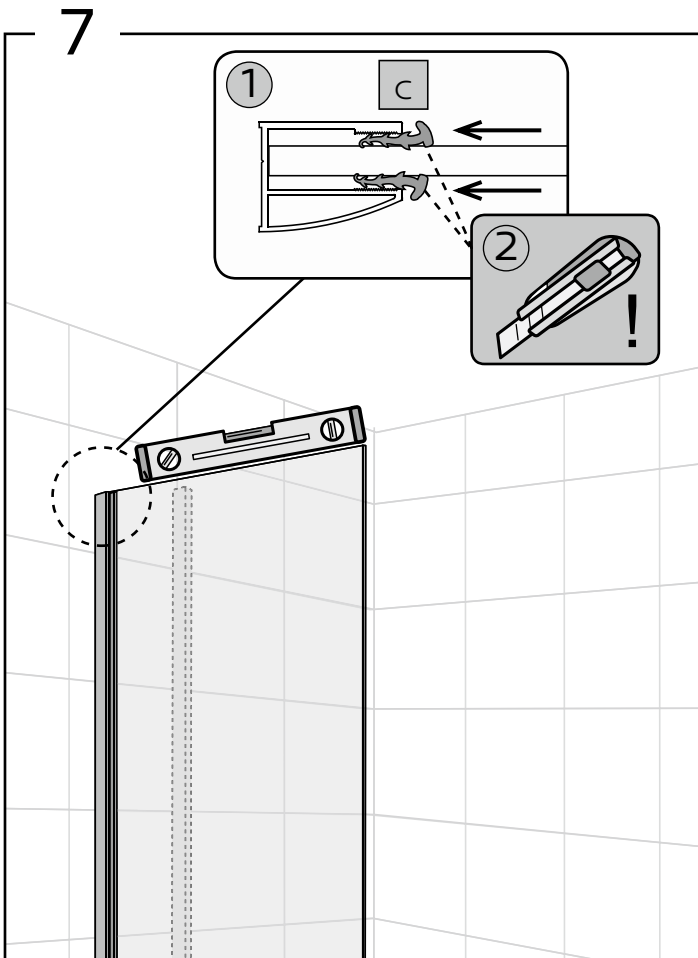
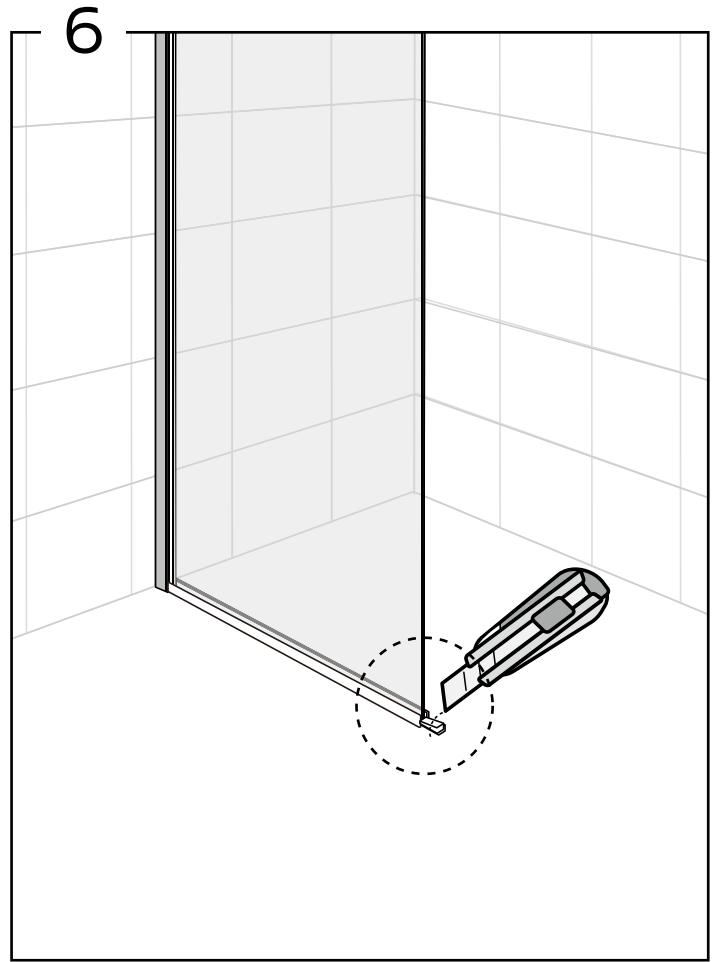
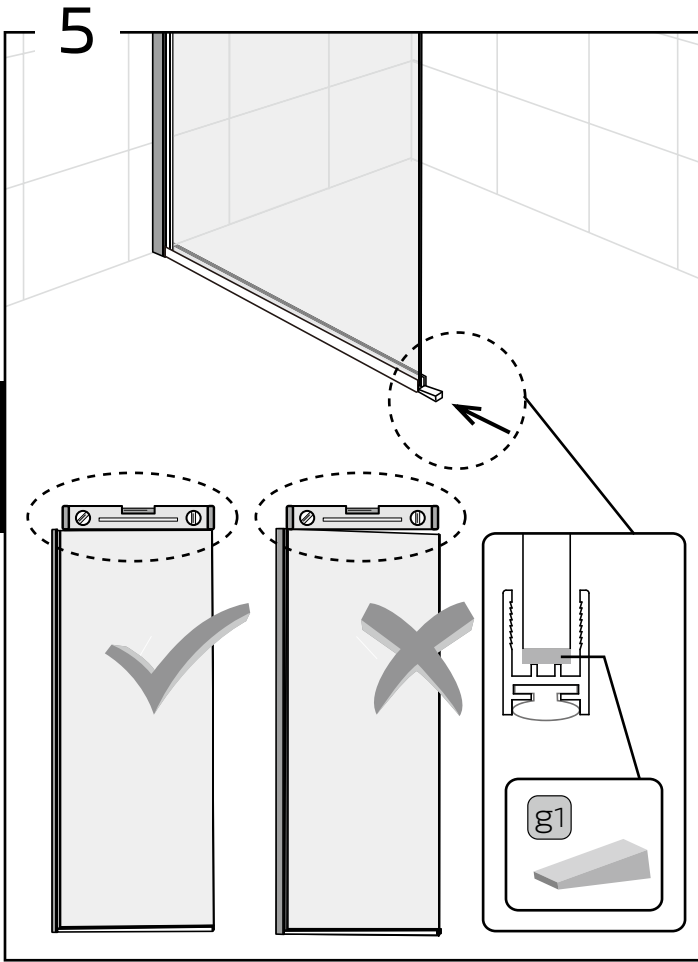

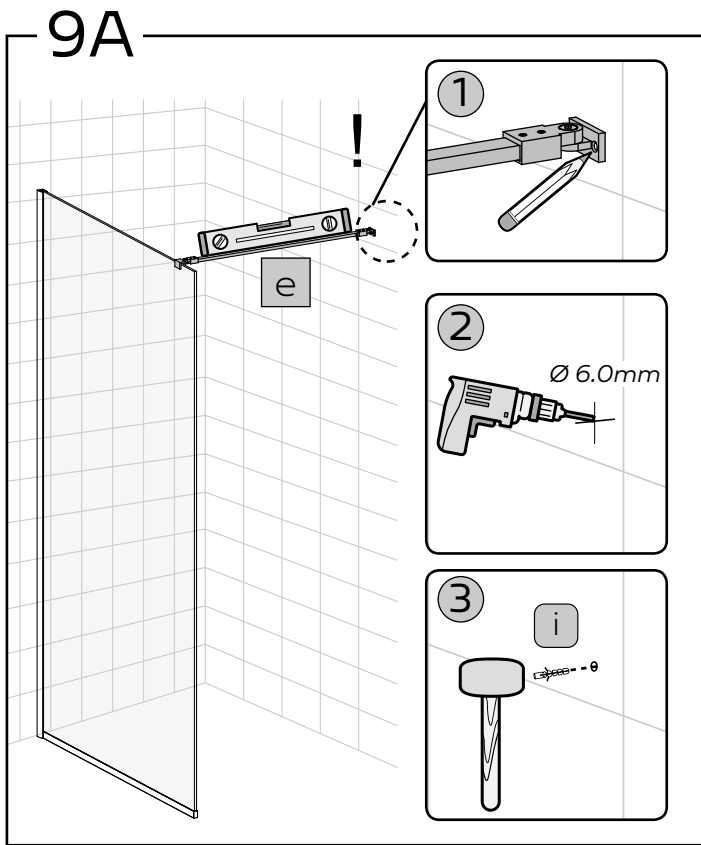

Ver.A

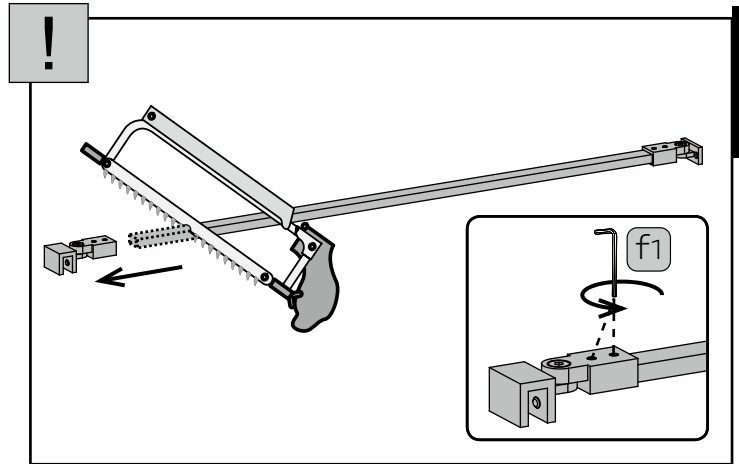
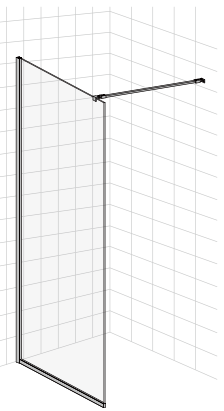

5(8)

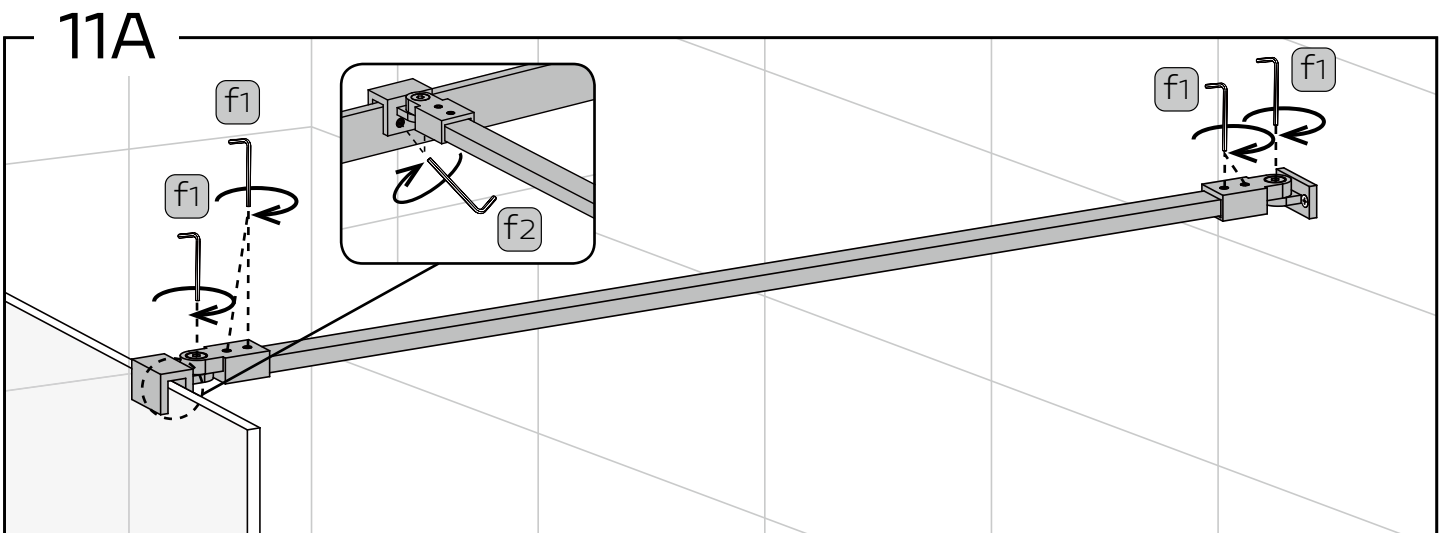
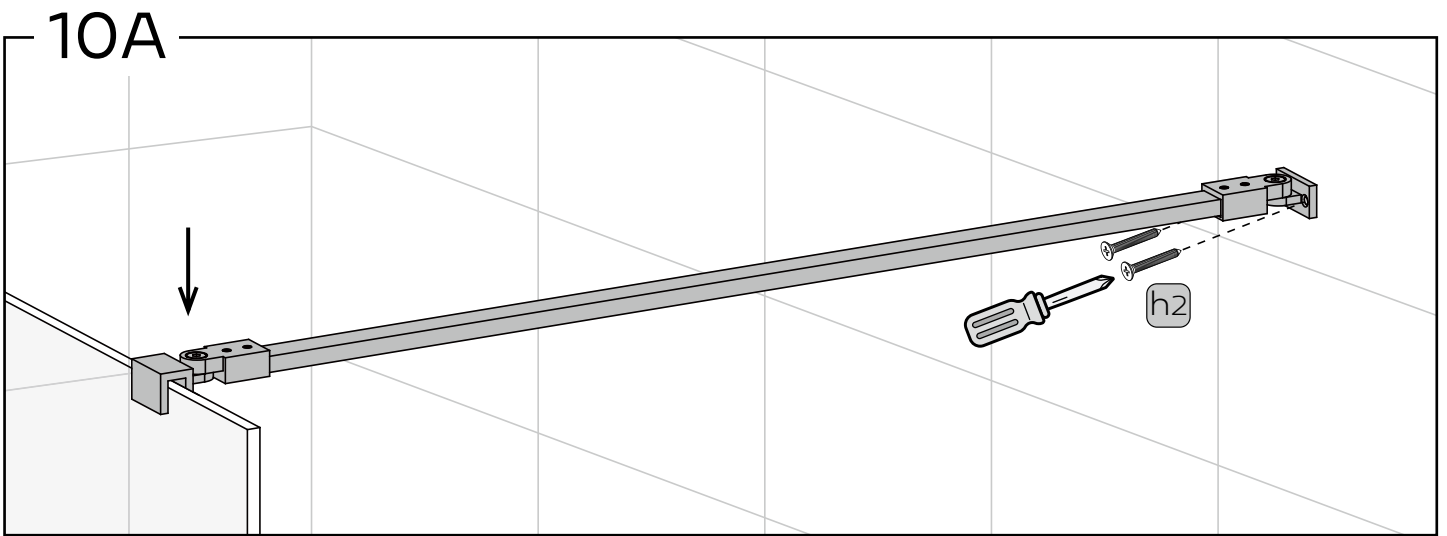

9B

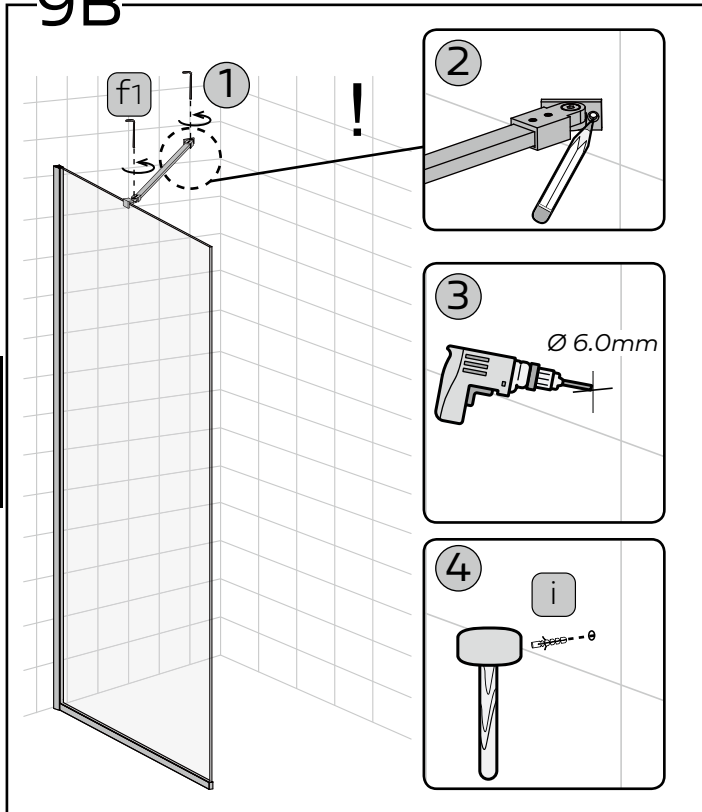

6(8)

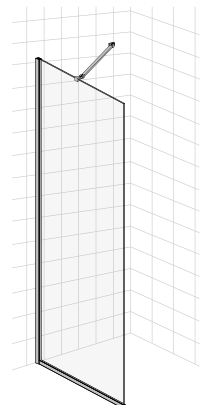

Ver.B

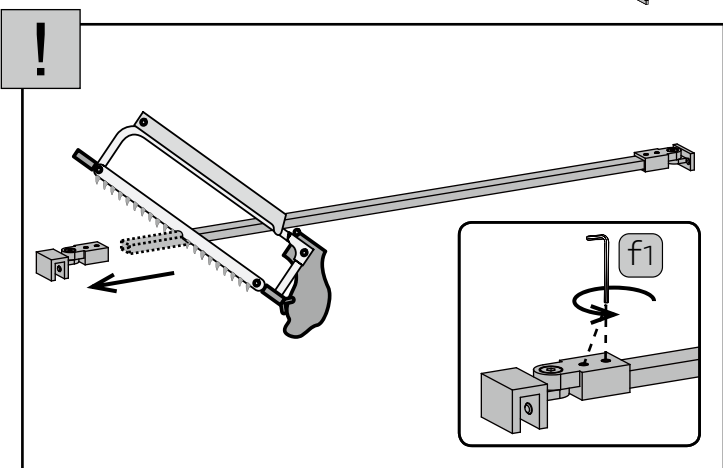

10B

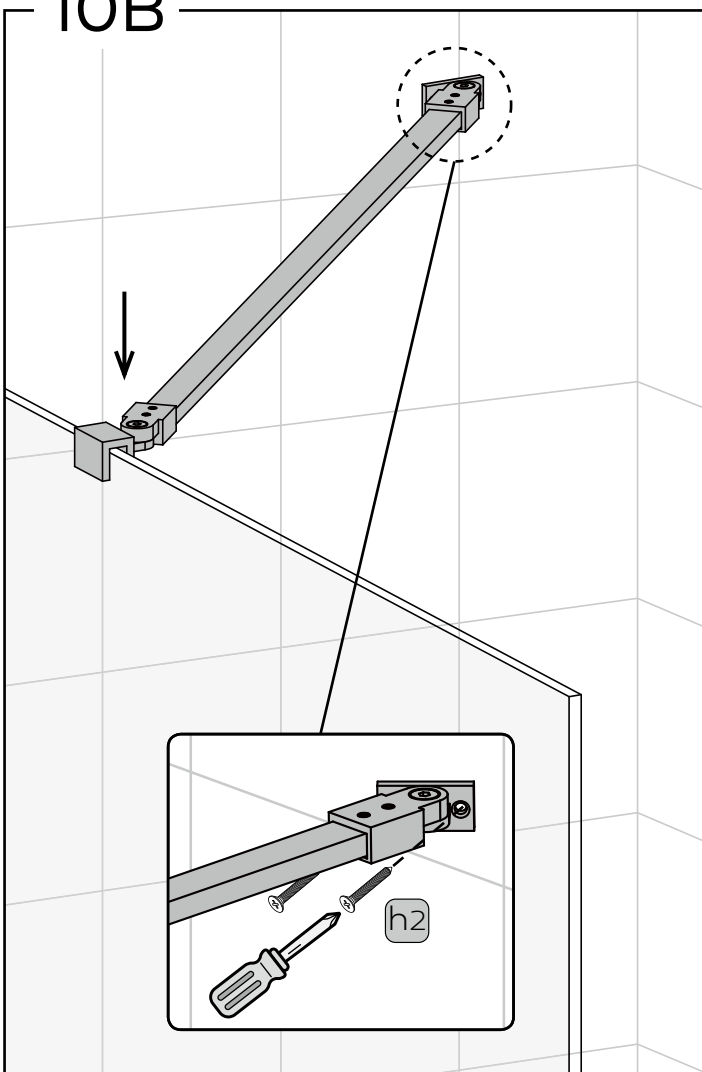

11B

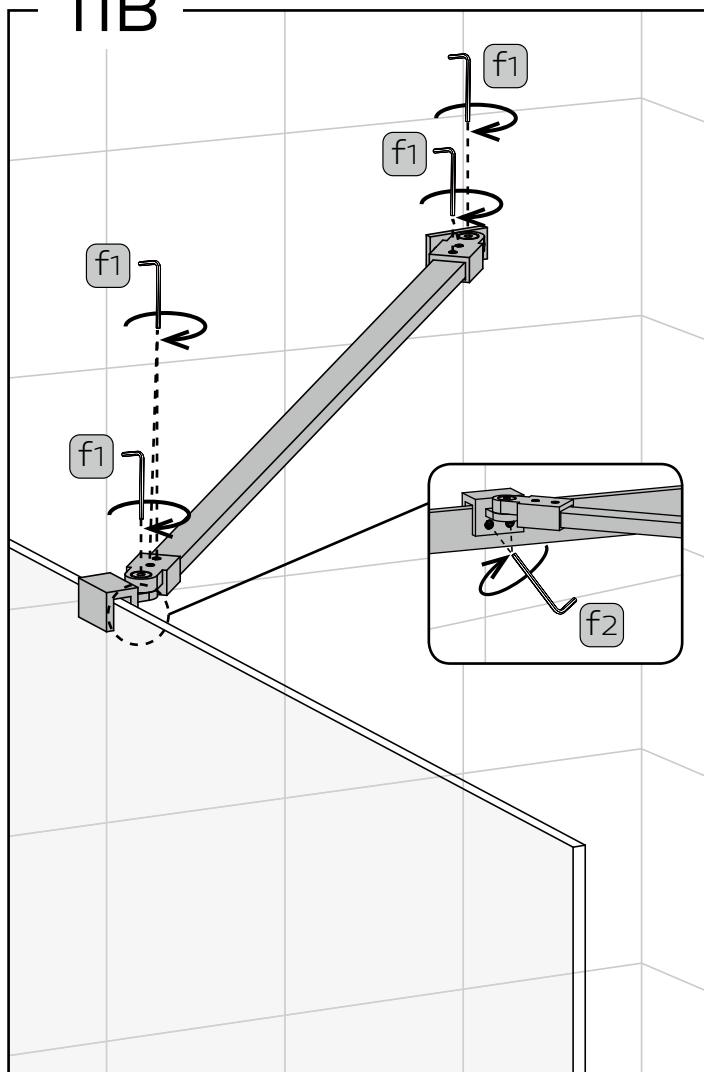

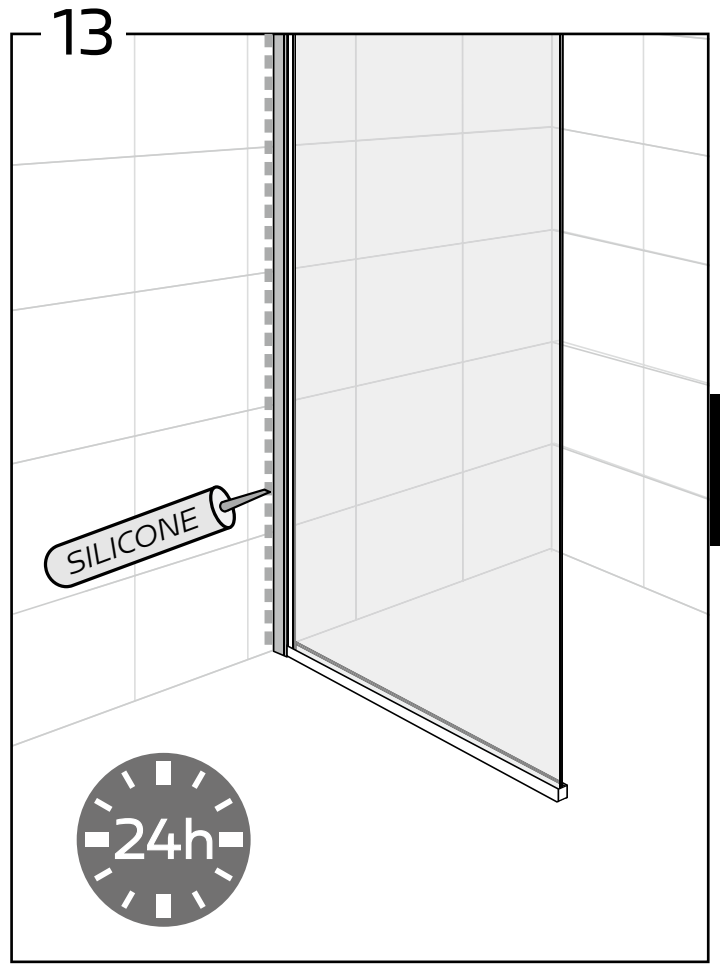
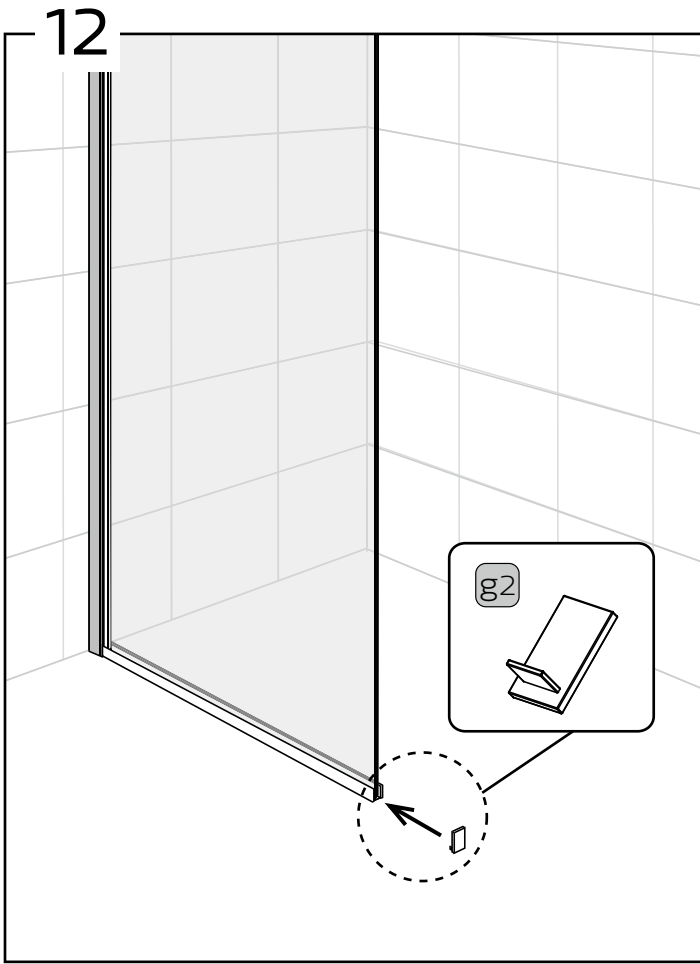



www.badnor.no